



## User Instructions

### Assembly of Flat Wall Touchpad Caddies

#### List of parts:

- 2 end frame bases (30" each), with casters (those on one end frame swivel, and those on the other do not)
- 2 end frame top pieces (30" each) w/white plastic caps
- 4 end frame vertical support pieces (32" each)
- 1 bottom cross frame with bottom pad supports attached
- 4 long top pieces (two top cross frames and two top pad supports)
- 20 bolts (3/8" x 1", zinc plated)
- 20 spring nuts (3/8" Unistrut)
- 20 washers (3/8" flat plated)

#### List of tools needed:

- 9/16-inch socket or wrench

#### Final Assembly

##### Spring nut instructions:

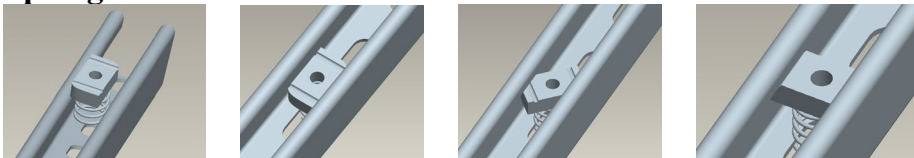

Your flat wall touchpad caddy comes partially assembled from the factory. To complete the assembly, follow these instructions:

- 1) Start by assembling the end frames. Each end frame consists of an end frame base and top (30"), and two end frame vertical support pieces (32"). Attach the support pieces to the top and bottom pieces using the 90-degree angle brackets already installed on the 30" pieces, and a spring nut, bolt and washer for each angle bracket, as shown in *Figure 1*.

*Figure 1*

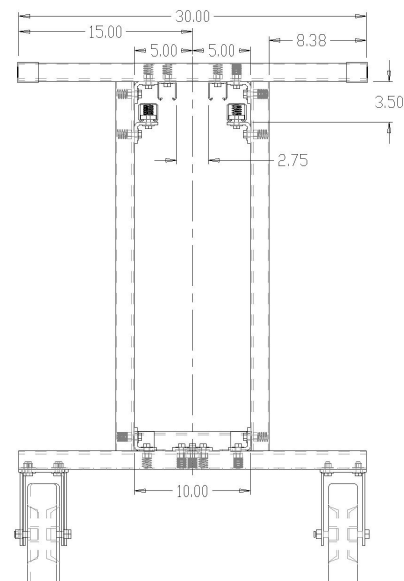

- 2) Install the bottom cross frame.
  - a. The bottom cross frame has a flat plate attached to each end. Use this plate and 2 spring nuts, 2 bolts and 2 washers to attach the bottom cross frame to one of the end frames, as shown in *Figure 2*. (Note that the wheel base extension should be oriented towards the inside of the caddy as shown)
  - b. Repeat for the other end.

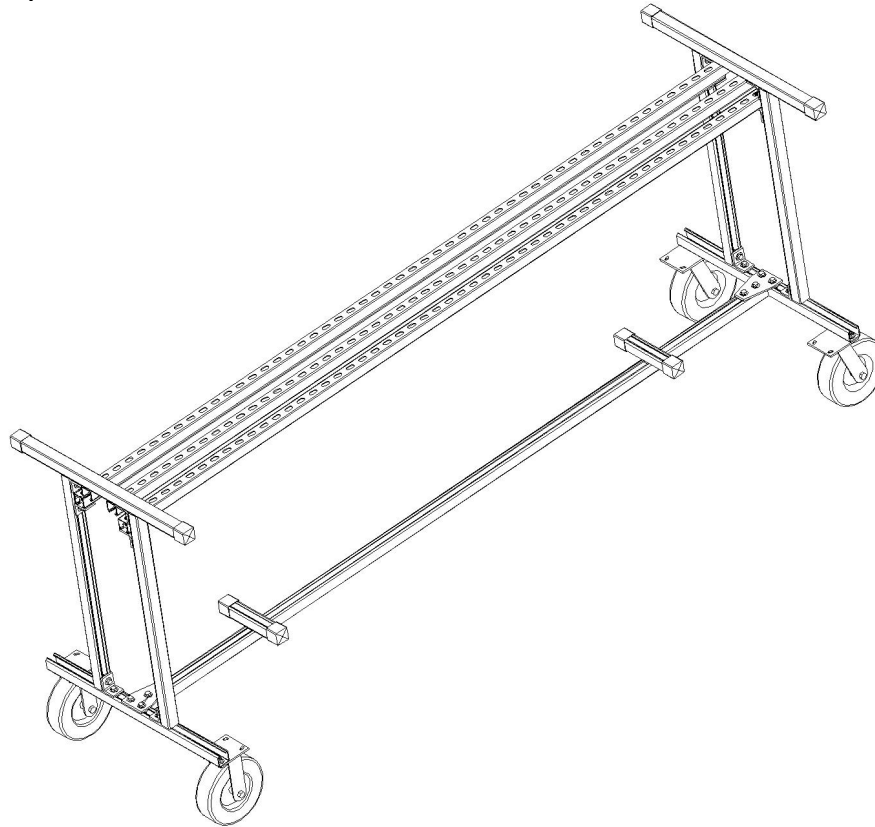

*Figure 2*

- 3) Install the top pad supports to the end frames at the 90-degree angle brackets that were installed on the end frame supports at the factory, using a spring nut, bolt and washer for each angle bracket, as shown.
- 4) Install the two top cross frames to the under side of the top of the end frames, using a spring nut, bolt and washer at each end, as shown. See dimensions in *Figure 1* for proper spacing.

Colorado Time Systems  
1551 E. 11<sup>th</sup> Street, Loveland, CO 80537  
Phone: 970-667-1000 x256 Fax: 970-667-1032 Toll free: 800-287-0653 ext. 256  
www.coloradotime.com E-mail: customerservice@coloradotime.com